

## 7/24 Digital Signage 500nit BNC-V Series



Geephon's BNC series smart displays feature a equal narrow bezel design, elevating aesthetics while maintaining clarity. Perfect for retail product and information displays, they adopt a higher-haze panel, reducing reflection and glare for a clear, immersive viewing experience. With vibrant colors and a slim profile, they effortlessly draw attention in any retail setting.

Versatile and widely applicable, they are ideal for supermarkets, banks, offices, malls, hotels, hospitals, and more.

BNC5523B-AA-05V



### • Optimal Visual Clarity

- High-performance image processor.
- Delivers true color expression and high resolution.
- Offers adjustable picture quality and white balance.



### • Seamless Wall Mounting (optional)

- Geephon's special mounting brackets kit (optional) ensures seamless and visually appealing equipment installation on walls.



### • Enhanced Component Design

- Lightweight design for easy handling.
- Constructed with high-strength aluminum alloy for durability.
- Modular components facilitate maintenance and replacement.



### • Anti-reflection Anti-glare Surface

- Higher haze panel
- Anti-reflection and anti-glare effects.

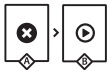

### • Fail Over Support



### • GPlay Convenient U disk

- Simply insert the U disk for automatic content copying and playback on the device upon booting



### • CMS / Remote Management Support (optional)

- Cloud-based remote management (CetusMSC) and CMS platform (GalaxyASC) support.
- Real-time monitoring of display status, parameters adjustment, and content distribution.
- Remote control via PC and Smart phone.



### • Built-in Speaker



### • Open API & SDK Support and RS232 Compatible



### • Landscape/Portrait Compatible

- Portrait and landscape display orientations.



### • OTA Firmware Update

- Enables remote firmware and application updates.
- Designed for seamless upgrades.



### • Fire Protection Certification



### • Extended Product Warranty

- Engineered for long-term durability.
- Guarantees reliable 24/7 operation.
- Comprehensive warranty ensures customer satisfaction and confidence.

## Specification

### Hardware Specification

|                          |   |
|--------------------------|---|
| Panel                    | IPS   |
| Display Size             | 55 inch   |
| Protection Glass         | N/A   |
| Protection Level         | IP 5X (Front Panel)   |
| Front Color              | Black   |
| Set Dimension (L*W*D)    | 1233.4 x 704.7 x 46.6mm   |
| Bezel Width Width(mm)    | 9.9mm   |
| Active Display Area(H*V) | 1209.6 x 680.4mm  |
| Resolution               | 3840 x 2160   |
| Type                     | 60Hz E-LED BLU  |
| Brightness(Typ.)         | 500 cd/m <sup>2</sup>   |
| Contrast Ratio(Typ.)     | 1200:1  |
| Haze                     | 25%   |
| Viewing Angle(H/V)       | 178°(H) X 178°(V)(CR≥10)  |
| Display Colors           | 1.07 G (8bits + FRC)  |
| Color Gamut              | 72%   |
| Response Time            | 8ms (Typ)   |
| Operation Hour           | 24/7  |
| Smart Solution           | PTC.DT1AHE-BAB  |
| Connectivity             | USB2.0*2, HDMI In*1, Ethernet(RJ45)*1, RS232(RJ45)*1, Line Out*1, Sensor*1, IR In*1 |
| Power Input Supply       | 100-240V AC, 50/60Hz  |
| Power Consumption        | 160W  |
| Speaker                  | 5W/8Ω *2  |
| IR                       | External connection   |
| Touch Technology         | N/A   |
| Camera                   | N/A   |
| Installation             | Wall mount  |
| VESA Mount               | 400 x 400mm   |
| Package(W*H*D)           | 1350 x 830 x 145mm  |
| Weight (kg)              | N.W: 18.3Kg G.W: 22.2Kg   |
| Operating Temperature    | 0°C~+40°C   |
| Storage Temperature      | -10°C~+60°C   |

### System Specification

|                      |   |
|----------------------|---|
| CPU                  | ARM Quad Core Cortex-A53 1.5G                 |
| GPU                  | ARM Mali-G52 2EE MC1                          |
| Operating System     | Android 9                                     |
| Cloud Advertising    | Optional                                      |
| Distribution System  |   |
| Cloud Splice System  | Optional                                      |
| Memory               | DDR 2G  |
| Storage              | EMMC 16GB                                     |
|                      | Ethernet (RJ45)                               |
| Ethernet             | WiFi 802.11b/g/n<br>4G LTE(FDD/TDD)(Optional) |
| Panel Image Rotation | 0/90/180/270/360 Angle Rotation               |
| Video Decoder        | MPEG-1/2/4,H.264,HEVC,VP8,VP9,AVS+,AVS2,AV1   |
| Audio Decoder        | MPEG-1.MPEG-2(layerI/II),MP3,AAC-LC,HE-AAC    |
| Picture Decoding     | JPG,JPEG ,PNG ,BMP                            |

### What's in the box

|                   |                                  |
|-------------------|----------------------------------|
| Power Cable       | x 1 Power cord (based on region) |
| Remote Controller | x 1                              |
| RS232 Adaptor     | x 1                              |

### Warranty

|          |                           |
|----------|---------------------------|
| Warranty | Three year or by contract |
|----------|---------------------------|

### Dimensions

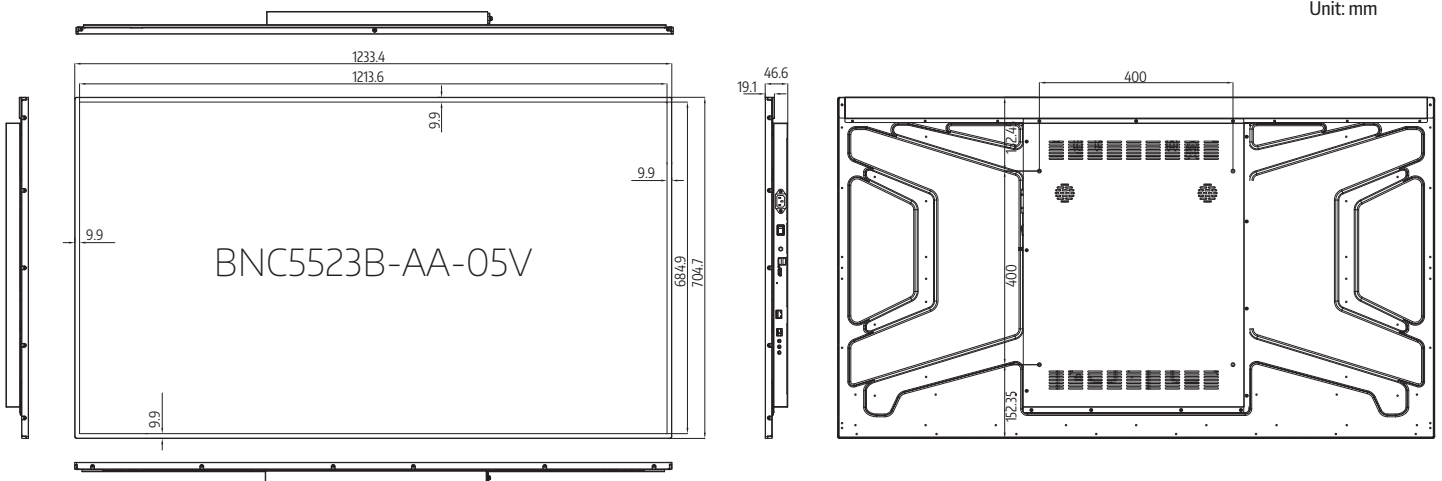

\* Compatibility may differ by equipment.  
 \* Software compatibility may change over time. Please contact your regional sales representative for details.  
 \* Specifications are subject to change without notice, so please contact sales team to verify before ordering.