

# GEEPHON

## 7/24 Digital Signage 500nit BNC-V Series



Geephon's BNC series smart displays feature a equal narrow bezel design, elevating aesthetics while maintaining clarity. Perfect for retail product and information displays, they adopt a higher-haze panel, reducing reflection and glare for a clear, immersive viewing experience. With vibrant colors and a slim profile, they effortlessly draw attention in any retail setting.

Versatile and widely applicable, they are ideal for supermarkets, banks, offices, malls, hotels, hospitals, and more.

BNC7523A-AA-05V



### • Optimal Visual Clarity

- High-performance image processor.
- Delivers true color expression and high resolution.
- Offers adjustable picture quality and white balance.



### • Seamless Wall Mounting (optional)

- Geephon's special mounting brackets kit (optional) ensures seamless and visually appealing equipment installation on walls.



### • Enhanced Component Design

- Lightweight design for easy handling.
- Constructed with high-strength aluminum alloy for durability.
- Modular components facilitate maintenance and replacement.



### • Anti-reflection Anti-glare Surface

- Higher haze panel
- Anti-reflection and anti-glare effects.

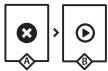

### • Fail Over Support



### • GPlay Convenient U disk

- Simply insert the U disk for automatic content copying and playback on the device upon booting



### • CMS / Remote Management Support (optional)

- Cloud-based remote management (CetusMSC) and CMS platform (GalaxyASC) support.
- Real-time monitoring of display status, parameters adjustment, and content distribution.
- Remote control via PC and Smart phone.



### • Built-in Speaker



### • Open API & SDK Support and RS232 Compatible



### • Landscape/Portrait Compatible

- Portrait and landscape display orientations.



### • OTA Firmware Update

- Enables remote firmware and application updates.
- Designed for seamless upgrades.



### • Fire Protection Certification



### • Extended Product Warranty

- Engineered for long-term durability.
- Guarantees reliable 24/7 operation.
- Comprehensive warranty ensures customer satisfaction and confidence.

## Specification

### Hardware Specification

Panel	IPS
Display Size	75 inch
Protection Glass	N/A
Protection Level	IP 5X (Front Panel)
Front Color	Black
Set Dimension (L*W*D)	1674.464 x 950.136 x 55.4mm
Bezel Width Width(mm)	9.9mm
Active Display Area(H*V)	1649.66 x 927.936mm
Resolution	3840 x 2160
Type	60Hz E-LED BLU
Brightness(Typ.)	500 cd/m <sup>2</sup>
Contrast Ratio(Typ.)	1200:1
Haze	25%
Viewing Angle(H/V)	178°(H) x 178°(V)(CR≥10)
Display Colors	1.07 G
Color Gamut	68%
Response Time	8ms (Typ)
Operation Hour	24/7
Smart Solution	PTC.DT1AHE-BAB
Connectivity	USB2.0*2, HDMI In*1, Ethernet(RJ45)*1, RS232(RJ45)*1, Line Out*1, Sensor*1, IR In*1
Power Input Supply	100-240V AC, 50/60Hz
Power Consumption	260W
Speaker	8W/8Ω *2
IR	External connection
Touch Technology	N/A
Camera	N/A
Installation	Wall mount
VESA Mount	400 x 500mm
Package(W*H*D)	1797 x 1076 x 180mm
Weight (kg)	N.W: 27kg G.W: 38kg
Operating Temperature	0°C~+40°C
Storage Temperature	-10°C~+60°C

### System Specification

CPU	ARM Quad Core Cortex-A53 1.5G
GPU	ARM Mali-G52 2EE MC1
Operating System	Android 9
Cloud Advertising	Optional
Distribution System	Optional
Cloud Splice System	Optional
Memory	DDR 2G
Storage	EMMC 16GB
	Ethernet (RJ45)
Ethernet	WiFi 802.11b/g/n 4G LTE(FDD/TDD)(Optional)
Panel Image Rotation	0/90/180/270/360 Angle Rotation
Video Decoder	MPEG-1/2/4,H.264,HEVC,VP8,VP9,AVS+,AVS2,AV1
Audio Decoder	MPEG-1.MPEG-2(layerI/II),MP3,AAC-LC,HE-AAC
Picture Decoding	JPG,JPEG ,PNG ,BMP

### What's in the box

Power Cable	x 1 Power cord (based on region)
Remote Controller	x 1
RS232 Adaptor	x 1

### Warranty

Warranty	Three year or by contract
----------	---------------------------

### Dimensions

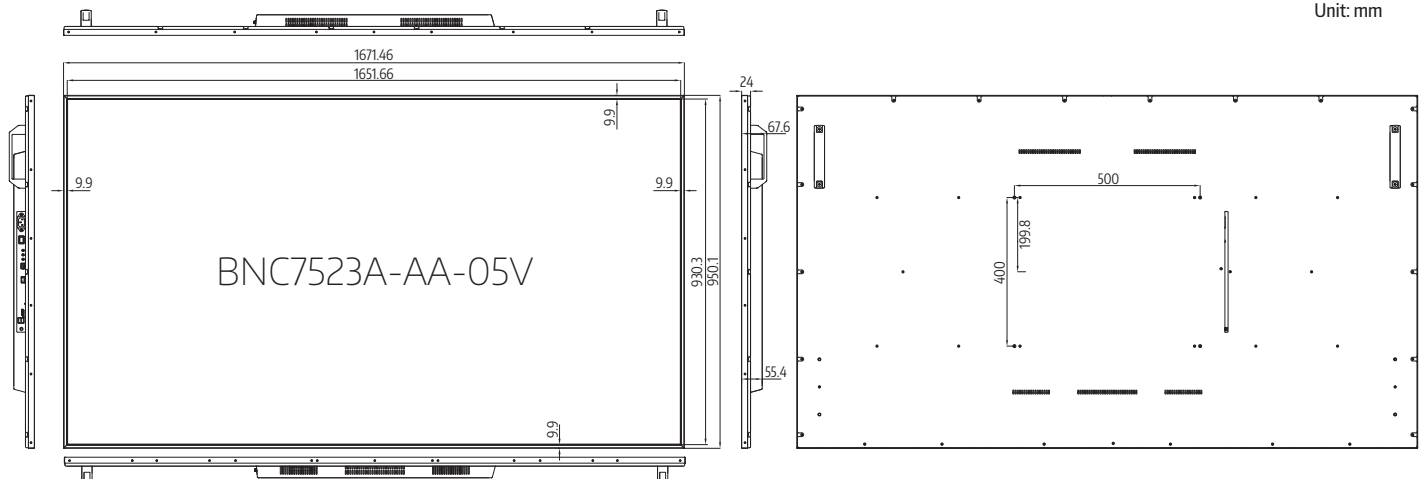

\* Compatibility may differ by equipment.

\* Software compatibility may change over time. Please contact your regional sales representative for details.

\* Specifications are subject to change without notice, so please contact sales team to verify before ordering